



C-650 D

Spare Parts Manual



Revathi Equipment Limited
Pollachi Road, Coimbatore - 641 021, India.

HYDRAULIC SECTION (continued)

Relief valve, Rotation/ fan	L 2580
Check valve	L 1215
Check valve	L 1273
V PUMP SECTION	
Pump unit assembly	Z 2898
Pump drive gear box assembly	Z 4384
Pump piston	Z 5421
Pump piston	L 0680
Pump, Gear	L 0663
Pump, Gear	L 0686
VI CONTROL STATION SECTION	
Control Station assembly	Z 5064
Instrument panel assembly	Z 7301
Remote pressure valve assembly	Z 5032
Valve, Remote pressure	2 PS4950
Rotation valve assembly	Z 5004
Valve, Rotation	L 2555
Valve mounting group	Z 5368
Double pilot check valve	L 1265
Over centre valve	L 2541
Throttle control valve assembly	Z 5018
Valve, Throttle control	L 2584
Unloader Valve assembly	1-030537
Volume control assembly	Z 1009
Pressure reducer valve	Z 1045
Level assembly	Z 4658
Limit switch assembly	Z 5027
VII MAIN STACKER SECTION	
Stacker valve assembly, Main	Z 5583
Stacker valve, Main	L 2815
VIII AUXILIARY STACKER SECTION	
Stacker valve assembly, Auxiliary	Z 4383
Stacker valve, Auxiliary	L 2562

AUXILIARY STACKER SECTION (Continued)

	Check valve	L 1220
IX	MAST SECTION	
	Mast weldment assembly	A 0147
	Mast raising group	Z 4915
	Hydraulic cylinder	V 7633
	Valve, Over centre	L 2541
X	PULL DOWN SECTION	
	Pull down assembly	Z 0676
	Hydraulic motor	L 2256
	Sprocket & bush assembly	Z 3210
	Valve mounting group	Z 2276
	Shuttle valve assembly	Z 0762
XI	ROTARY HEAD SECTION	
	Rotary head assembly	Z 0810
	Hydraulic motor	L 2255
XII	POWER BREAKOUT SECTION	
	Power breakout assembly	Z 5768
	Hydraulic cylinder	V 7650
XIII	DRILL STEM SECTION	
	Stem wrench assembly	Z 1156
	Hydraulic cylinder	V 7635
XIV	BARREL LOADER SECTION	
	Barrel loader assembly	Z 5710
	Hydraulic cylinder	V 7635
	Hydraulic cylinder	V 7708
	Check valve assembly	Z 3815
	Double pilot check valve	L 1265
	Loader adapter group	Z 0590
XV	PROPEL SECTION	
	Propel assembly	Z 0771
	Crawler weldment	Z 0770
	Propel motor	L 2260

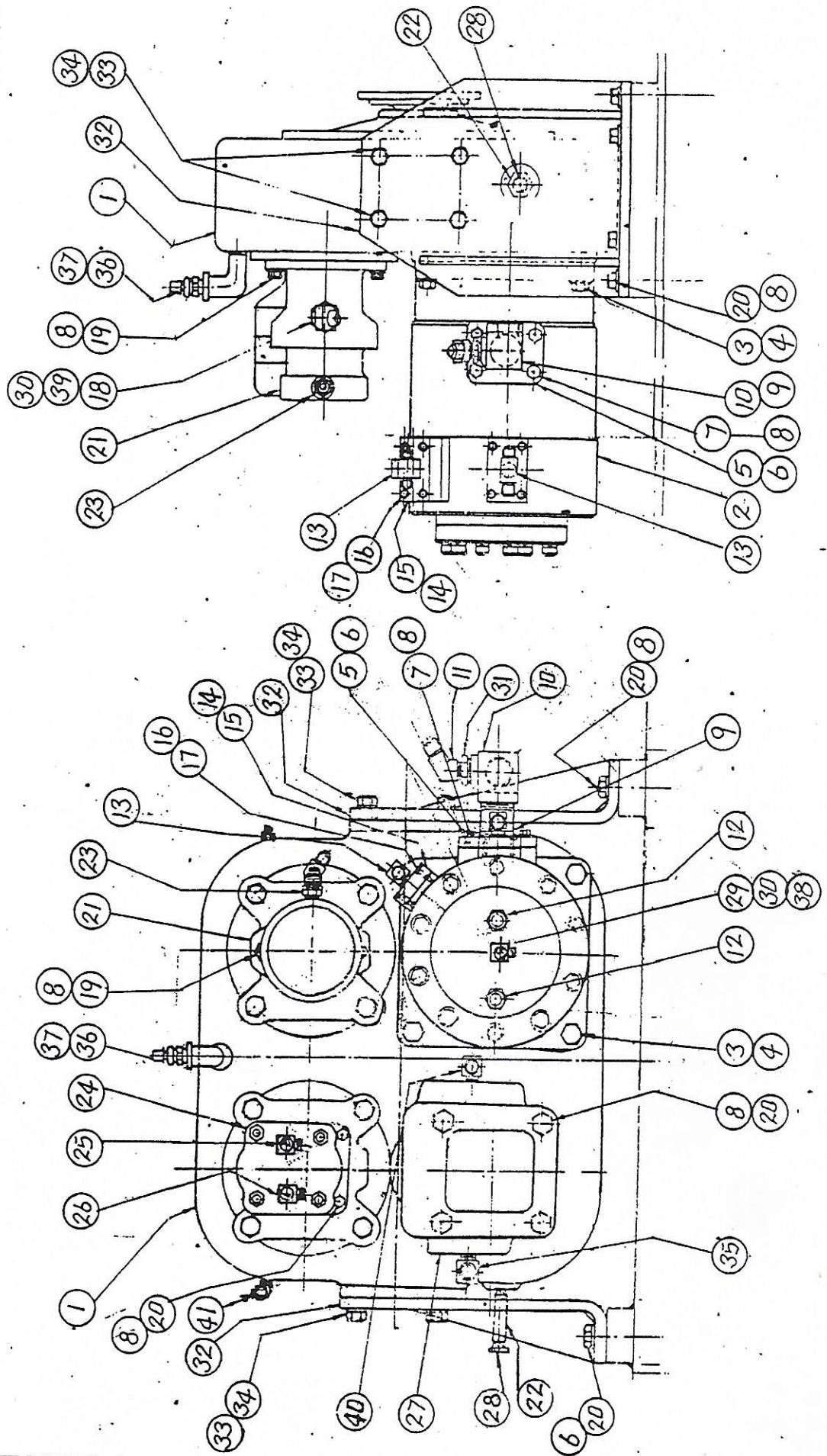

1	3
<i>AA</i>	
DRAWN	CHECKED

PUMP UNIT ASSY

REVATH CP EQUIPMENT LIMITED
 COIMBATORE-641 021



<u>ITEM</u>	<u>QTY</u>	<u>STOCK NO.</u>	<u>DESCRIPTION</u>
1	1	Z4384	PUMP DRIVE GEAR BOX ASSY
2	1	Z5421	PUMP, PISTON MODIFIED
3	4	418PS182	CAPSCREW
4	4	15PS454	LOCK WASHER
5	1	D2202	ADAPTER FLANGE
6	1	231PS2988	'O' RING
7	4	247PS182	CAPSCREW
8	22	11PS454	LOCK WASHER
9	1	137PS135	PIPE NIPPLE
10	1	H4641	ADAPTER SPECIAL
11	1	13PS2272	ADAPTER 45 DEGREE
12	2	24PS2451	ADAPTER, ST.
13	2	9PS2278	ADAPTER TEE
14	2	D3608	ADAPTER FLANGE
15	2	219PS2988	'O' RING
16	8	37PS400B	SOC. HEAD CAPSCREW
17	8	8PS552	LOCK WASHER
18	1	H1932	ADAPTER ST.
19	2	71PS400B	SOC. HEAD CAPSCREW
20	16	242PS182	CAPSCREW
21	1	L0680	PISTON PUMP <i>Feed</i>
22	1	<i>H6860</i>	<i>ADAPTER ST. SPECIAL</i>
23	1	6PS2451	ADAPTER, ST.
24	1	L0663	GEAR PUMP <i>Inst</i>
25	1	<i>13-PS 2274</i>	ADAPTER, 90°
26	1	<i>14-PS 2274</i>	ADAPTER, 90°
27	1	L0686	GEAR PUMP <i>Cooler motor</i>
28	1	N7964	OIL LEVEL INDICATOR
29	1	<i>H4622</i>	ADAPTER, ST. FEMALE
30	2	916PS2988	'O' RING

DRN: *AR*

CHD:



REVATHI CP EQUIPMENT LIMITED
COIMBATORE-641 021

PUMP UNIT ASSY.

Z2898

2

3

31	1	S25-5100	REDUCER BUSHING
32	2	A7320	SUPPORT, GEAR BOX
33	8	363PS182	CAPSCREW
34	8	13PS454	LOCK WASHER
35	1	H1578	ADAPTER 90 DEGREE
36	1	Z1969	BREATHER
37	1	S111-5100	BUSHING, REDUCER
38	1	15-PS 2274	ADAPTER 90°
39	1	11PS2272	ADAPTER 45 DEGREE
40	1	H 1451	ADAPTER 90°
41	1	150-PS 115	STREET ELBOW 90°

DRN: <i>AR</i>	CHD:					
		REVATHI CP EQUIPMENT LIMITED COIMBATORE-641 021	<i>PUMP UNIT ASSY.</i> <i>Z 2898</i>	<table border="1"> <tr> <td>3</td> </tr> <tr> <td>3</td> </tr> </table>	3	3
3						
3						

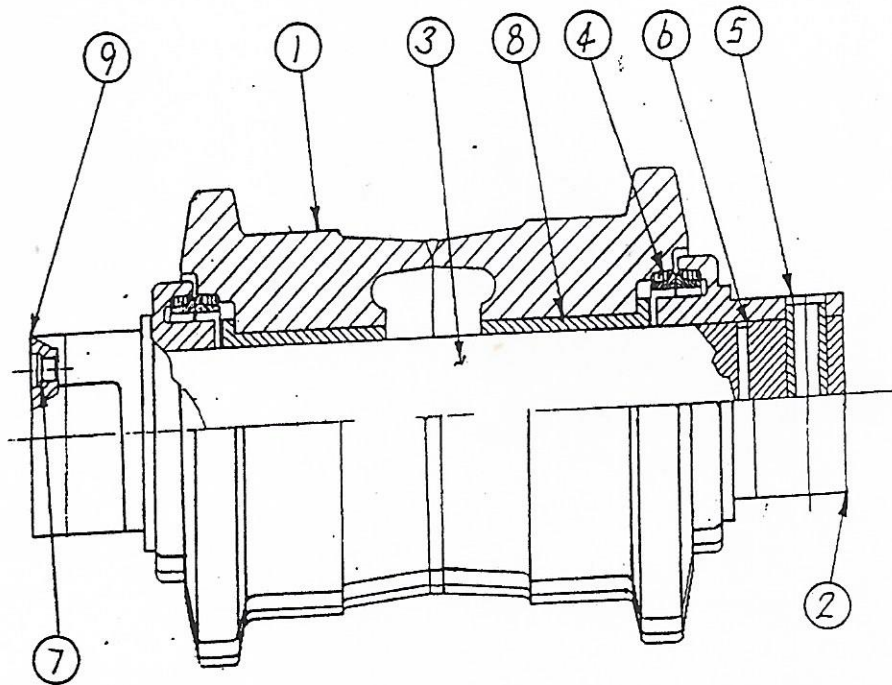

<u>ITEM</u>	<u>QTY</u>	<u>STOCK NO.</u>	<u>DESCRIPTION</u>
1	1	W1932 103	ROLLER ASSY
2	1	W1907 129	ROLLER END COLLAR
3	1	W1907 133	ROLLER SHAFT
4	2	W1907 173	SEAL GROUP
5	2	W1907 130	SPRING DOWEL
6	2	W1907 132	SEAL O RING (SHAFT)
7	1	W1932 104	PLUG
8	2	W1907 174	BRONZE BUSHING
9	1	W1932 105	ROLLER END COLLAR-PLUG SIDE

DRN: 55

CHD:



REVATHI CP EQUIPMENT LIMITED
COIMBATORE-641 021

ROLLER GROUP
W1932 101

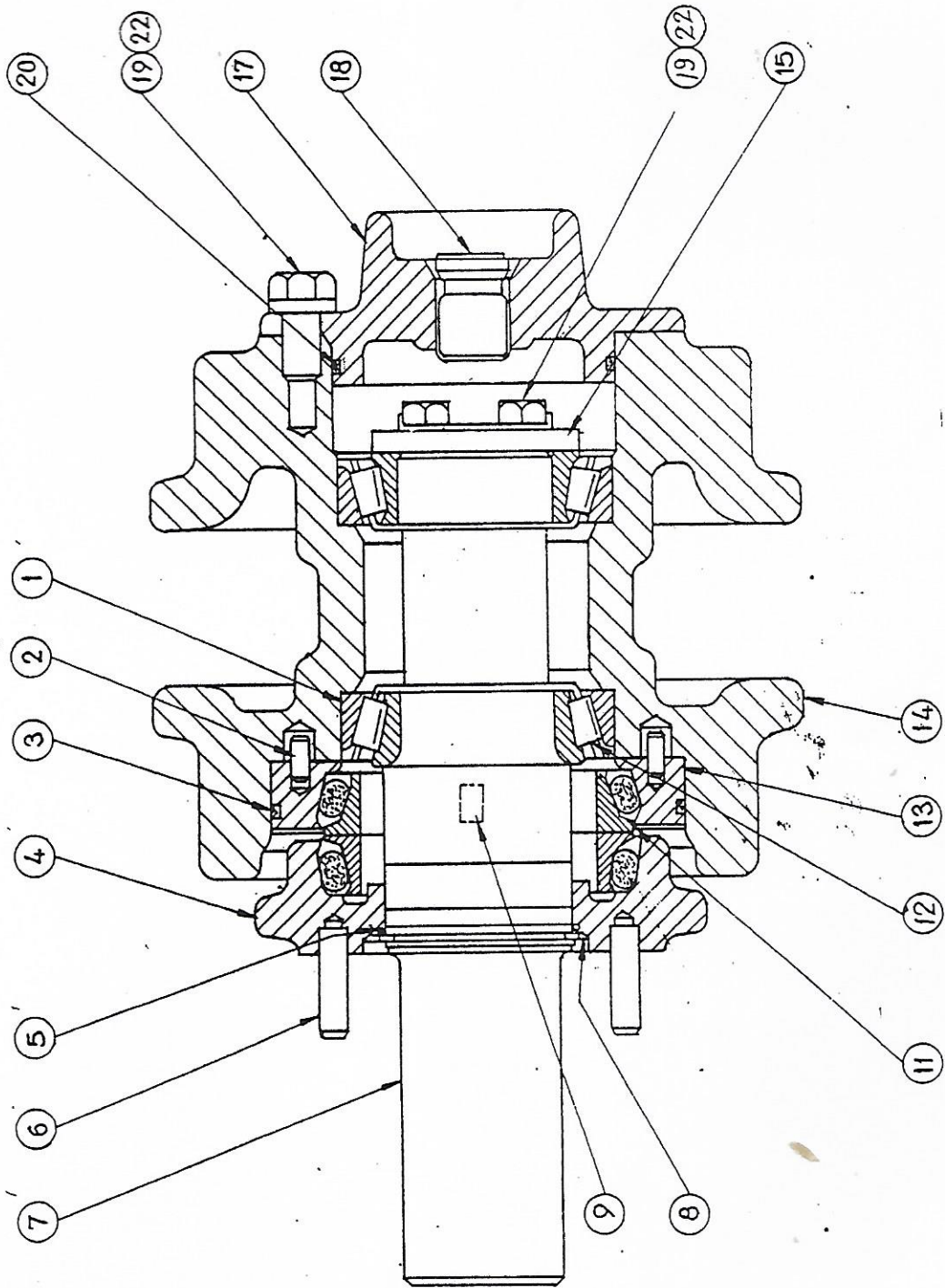

REVATHI CP EQUIPMENT LIMITED
 COIMBATORE-641 021

TRACK CARRIER ROLLER GROUP

W1 901 1 61

DRAWN

CHECKED

STOCK No.

1
2

W1 901 1 61

<u>Item</u>	<u>Qty</u>	<u>Stock No.</u>	<u>Description</u>
1	2	W1901 1 40	Cup
2	2	W1901 1 41	Dowel (part of supply assy W1901 1 76)
3	1	W1901 1 42	Seal.
4	1	W1901 1 43	Collar assy
5	1	W1901 1 44	Seal
6	2	W1901 1 75	Dowel (Part of Collar assy W1901 1 77)
7	1	W1901 1 33	Shaft
8	1	W1901 1 47	Ring
9	2	W1901 1 48	Cork
11	1	W1901 1 36	Seal group
12	2	W1901 1 51	Cone
13	1	W1901 1 52	Support assy
14	1	W1901 1 53	Roller
15	1	W1901 1 37	Plate
17	1	W1901 1 56	Cover
18	1	W1901 1 38	Plug
19	5	W1901 1 39	Bolt
20	1	W1901 1 30	Seal
22	5	W1901 1 60	Lock washer

TRACK CARRIER ROLLER GROUP

W1901 1 61

0
1
2
3
4
5
6
7
8
9